

## **Signs (amended 2-5-2020)**

Please refer to the “Sign Placement Diagram” at the end of this document for the placement of all types of signs.

### *For Sale or Lease/Rent Signs*

- No more than one professionally lettered For Sale or For Lease/Rent sign may be placed on a lot. The sign is to be placed in the yard of the residence and not fastened to the building. In areas where signs must be placed in the common areas, the sign is to be placed as close as possible to the home and not near the curbs or street. Golf course lots may have one additional professionally lettered For Sale or For Lease/Rent sign placed in the rear yard of the residence and not fastened to the building or fencing, or hang over rear property line. Where a sign is not possible or prohibited to be placed in a yard or common area, one sign may be displayed within one window of the property.
- The sign must not exceed 18 inches by 24 inches and it may be double sided. The overall height of the sign post may not exceed five feet.
- Two agent riders may be attached to the sign, each not to exceed 6 inches by 24 inches. Both agent riders may be attached at the bottom, but only one agent rider may be attached at the top.
- Signs may include one tube or box for distribution of brochures. No other forms of advertising, including but not limited to flags, balloons, banners, or streamers, are permitted on or near For Sale or For Lease/Rent signs.
- The sign and signpost must be removed from the home the day after close of escrow or signed lease.

Westbrook Village Association has available, for a deposit and a small rental fee, professional For Sale or Rent signs for properties that are offered for sale or rent by owner.

### *Open House/Garage Sale/Estate Sale Directional Signs*

Open House/Garage Sale/Estate Sale directional signs that give directions to a property which is for sale or hosting a garage or estate sale, to which the public is invited for a walk in inspection, are permitted under the following conditions:

- Directional signs must be professionally lettered and must not exceed three feet in height. No other forms of advertising, including but not limited to flags, balloons, banners, or streamers, are permitted on or near directional signs. Signs must be in good condition – not torn, soiled or faded.
- Directional signs must provide contact information on the back of all signs.
- One (1) directional sign per turning movement within a 1 mile radius of the property is permitted.
- Directional signs are permitted to be placed on another owner’s property, if the other owner’s permission has been previously granted.
- Directional signs are permitted to be placed on the common areas with the following exceptions:
  - Directional signs are not permitted to be placed at any location on the east or west sides of 91<sup>st</sup> Avenue, or within fifty (50) yards of 91<sup>st</sup> Avenue and W. Westbrook Parkway/Country Club Parkway/W. Chino Drive.
  - Directional signs are not permitted to be placed at any location on the north side of Unions Hills Road or within fifty (50) yards of Union Hills and W. Westbrook Parkway/Country Club Parkway.
  - Directional signs are not permitted to be placed at any location on the south side of Beardsley Road.
  - Directional signs are not permitted to be placed at any location on the west side of 83<sup>rd</sup> Avenue or within fifty (50) yards of 83<sup>rd</sup> Avenue/W. Village Parkway.
  - Directional signs are not permitted to be placed on the sidewalks, roadways, medians (any public rights-of-way). Directional signs must be outside of site visibility triangles.
- WVA will pick up non-professional and incorrectly placed signs.

### *Open House Hours*

Open House Hours for a property that is for sale or lease/rent to which the public is invited for a walk in inspection are permitted between the hours of 8:00a.m. and 6:00p.m. any day of the week.

### *Garage/Estate Sale Hours*

Garage/Estate Sale Hours for a property that is hosting a sale to which the public is invited for a walk in

inspection are permitted from daylight to dusk any day of the week.

Westbrook Village Association has available, for a deposit and a small rental fee, professional Garage Sale signs for properties hosting a garage sale.

All directional signs must be removed from dusk to daylight.

# Sign Placement Diagram

Including Garage / Yard Sale, Estate Sale, For Sale, Open House, For Rent

## RESIDENTIAL STREETS

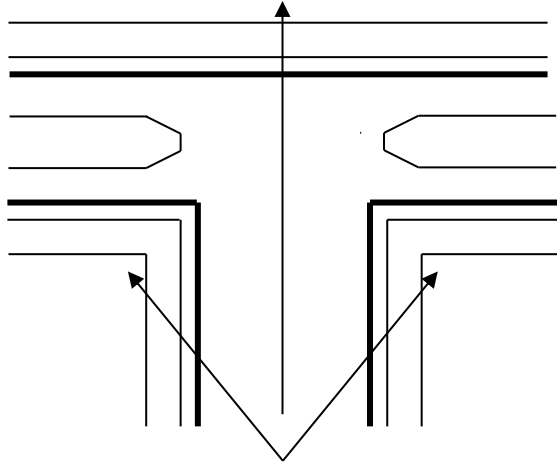

Place signs behind sidewalk ONLY

## RESIDENTIAL INTERSECTIONS

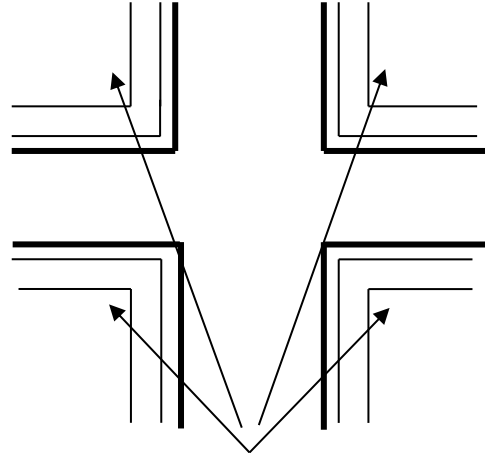

Place signs behind sidewalk ONLY

## DO NOT PLACE ANY SIGNS AT THE FOLLOWING LOCATIONS

### GOLF COURSE OR REC CENTER PROPERTY

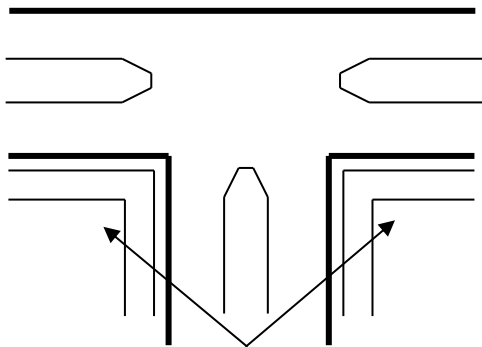

Place signs ONLY at corners Across from these Areas behind sidewalk

### WESTBROOK ENTRANCES

WEST SIDE OF 83<sup>RD</sup> AVE.

SOUTH SIDE OF BEARDSLEY ROAD

EAST or WEST SIDE OF 91<sup>ST</sup> AVE.

ON THE SIDEWALK, ROADWAY, OR CENTER ISLAND

The City of Peoria does not allow signs to be placed on the sidewalks, roadways, medians (any public right of way) or site visibility triangles.